

1987-95 JEEP YJ HOOD HOLD DOWNS

INSTALLATION INSTRUCTIONS

Page 1 of 2

Note: Designed to work with stock hood and fender and may not be compatible with some aftermarket hoods, fenders and fender flairs.

INSTALLATION:

- Reuse all original nuts securing hood hooks to vehicle.
- Adjust hold down to apply some pressure holding hood
- down to prevent rattles.
- Use two 13mm nuts to tighten jam nuts to adjusting turn buckle.
- Note direction of install on hood isolator pad
- (note is on the part itself)
- Direction of pin routing is user preference.

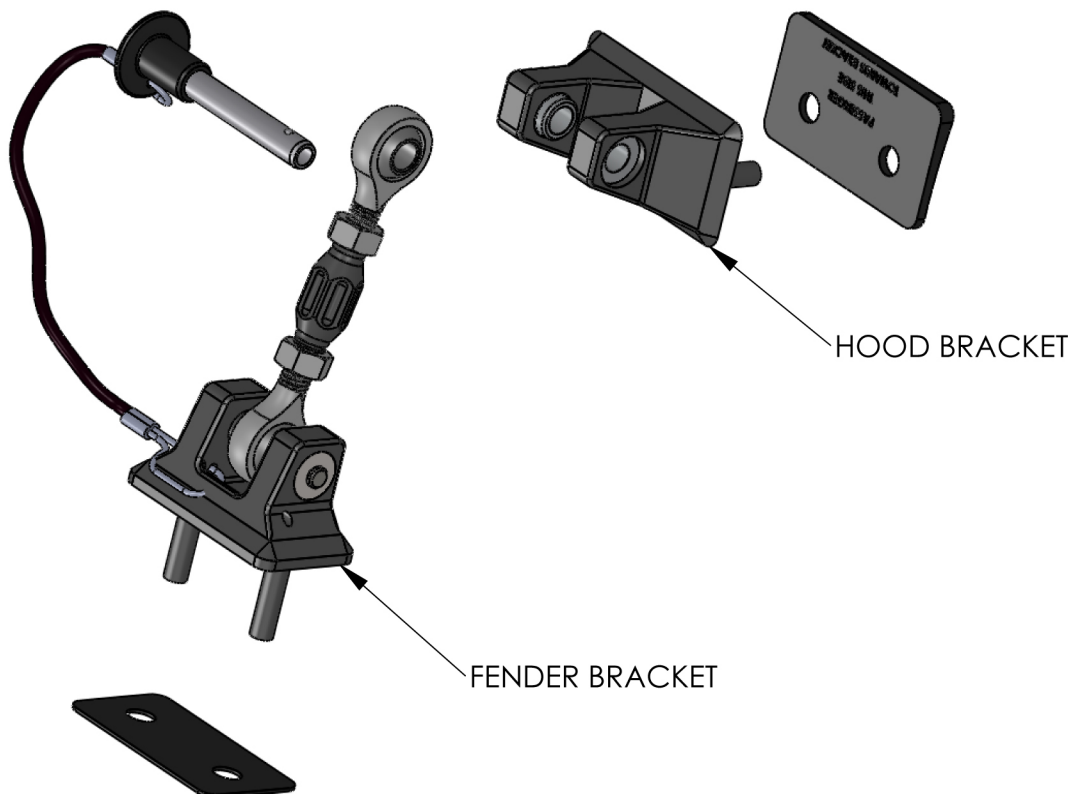

1987-95 Jeep YJ
Hood Hold Down Installation

1. Open hood.
2. Remove two nuts securing stock hood hook to fender and remove from both sides of vehicle.
3. Install Drake Off Road fender brackets on both sides of vehicle with original hardware. Make sure to place rubber pad between fender and bracket. Tighten securely.
4. Remove hook catch on both sides of hood.
5. Install bracket on Jeep with rubber pad between bracket and hood.
6. Make sure turn buckles are flipped out of the way and resting on the fenders.

ALWAYS MAKE SURE TURNBUCKLES ARE FLIPPED OUTWARD BEFORE CLOSING HOOD TO AVOID DAMAGE!

7. Close hood.
8. Line up turnbuckle and install quick release pin. Direction of the Quick release pin is user preference and it can be installed from the front or the back.

Setup

1. Make sure jam nuts are threaded all the way against the heim joints as seen in the previous picture.
2. Gently apply downward pressure to hood while turning billet aluminum turn buckle to adjust hood down until it contacts the rubber pad. Adjustment is set to personal preference but we've found that spinning the turnbuckle until the quick release pin is almost difficult to pull out works best. With it adjusted to this tension we are able to gently push down on the hood to relieve the pressure on the pin and pull it out at the same time.
3. Once adjusted to your preferred tension use two 13mm wrenches to tighten jam nuts on turnbuckle against the billet aluminum center piece. Once adjusted properly you should not need to use turnbuckle to open and close your hood.